



Kroeplin
Längenmesstechnik

Mechanical and electronic
length measuring instruments for
internal and external measurements

New generation of internal and external measuring quicktest gauges

Ergonomically designed with new IP classification. The gauges provide a digital / analog display for better reading. The quicktest gauges includes custom designed test programs, measuring contacts, absolute- and relative measuring programs and red/green display for tolerance measurement.



Ever since its foundation in 1883 Kroepelin have been involved in development and production of handy reliable and precise gauges for the measurement of lengths and thicknesses, especially for the metalworking industry. Thus the quick test system was created, which was the basis for all further innovations and also for the electronic dial indicators.

New mechanical gauges

- IP 65
- Small measuring force difference
- Better reading
- Larger measuring ranges

New electronic gauges

- IP 67
- Reduced weight
- Better digital display
- Analog segment display
- Ergonomically designed
- USB and Mitutoyo interface



Experience is the solid foundation for quality. Careful observation and analysis of the market, flexible realization of requirements, convincing measuring concepts - that is the philosophy that makes Kroepelin successful. Today like before more than 125 years.



Definitions

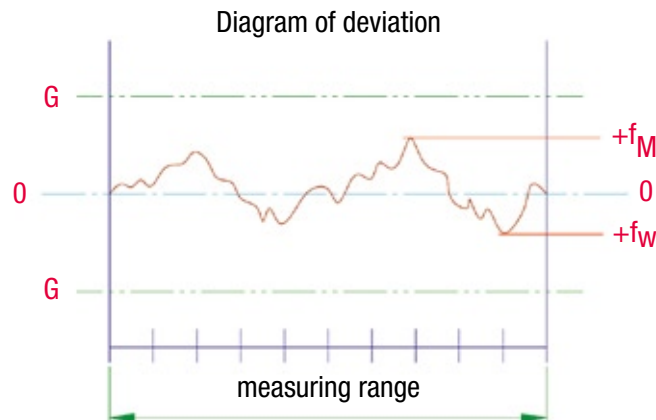

The individual diagram of deviation you can see in the certificate of quality which will be sent with every gauge.

Definitions

Terms of length test techniques see DIN 2257 part 1 and part 2 and International Vocabulary of Basic and General Terms in Metrology

Foundations

This instruction follows approximately the checking instructions of the German standard DIN 878 for dial gauges and the checking instructions for caliper gauges according to VDI/VDE/DGQ 2618, page 13. The gauges are referred to as gauges with absolute measurement and adjustable zero point.

Range of indication Azb

The range of indication is the range between the highest and the lowest indication.

Measuring range Meb

The measuring range of a gauge represents the range of measuring values in which given error limits must not be exceeded.

Measuring span Mes

The measuring span is the difference between starting value and final value of the measuring range.

Scale interval Skw

The scale interval is the modification of the value of the value of a measured variable that causes the modification of the indication by one interval. The scale interval is indicated in the unity of the measured variable.

Deviation in the measuring range f_M

The deviation in the measuring range f_M represents the distance of ordinates between the highest and the lowest position in the deviation diagram, when the movable caliper arm closes. The tolerance field G for f_M is symmetrically positioned to the zero line.

Repeat precision f_W

The repeat precision f_W is a characteristic value for deviations of the measured quantity within the measuring range in the same motion direction of the movable caliper arm (usually n=5). This margin of error is designated as repeat limit r.

Measuring force F_{min}, F_{max}

When the caliper arm closes, the measuring force F_{min}/F_{max} is determined at the top of the movable caliper arm. The gauge must be held in vertical position >= 200 mm

Features

- Certificate of quality
- Reliable repeatability
- Scales are well arranged and easy to read
- Scale interval from 0,005mm up
- Tolerance marks easy to read
- All mechanical gauges are also available in "INCH"
- The electronic gauges can be switched over to "INCH"
- Measuring contacts are mainly made of carbide
- Electronic gauges with analog / digital display for better reading
- Mitutoyo interface
- USB interface
- Ergonomically designed
- Measuring programs and contacts for different applications
- Absolute and relative measurement
- Red / Green LED for tolerance measurement
- Special solutions possible
- Stand holding unit for serial measurement of small parts
- Convincing price for convincing performance

INTERNAL MEASUREMENT



G102



H105



G210



H210



G230



H230

Measuring capacity

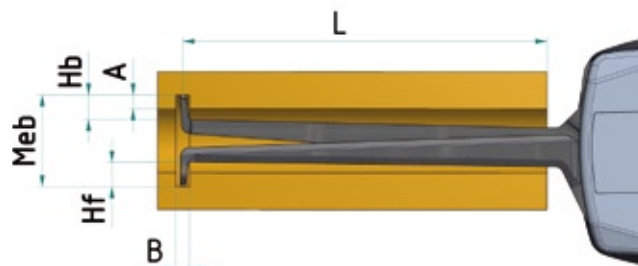

- Measuring contact movable Hb
- Measuring contact fixed Hf
- Measuring depth L
- Groove depth A
- Groove width B

Application range up to 50 mm

Type	Measuring span Mes [mm]	Measuring range Meb [mm]	Range of indication AzB [mm]	Scale interval Skw [mm]	Permissible errors G [mm]	Repeatability limit r [mm]	Measuring force min. [N]	Measuring force max. [N]	Weight [g]	Protection class	Measuring contact movable Hb [mm]	Measuring contact fixed Hf [mm]	Type of measuring contact [mm]	Groove depth A [mm]	Groove width B [mm]	Measuring depth L max. [mm]	Picture	Electronic E Mechanical M	Wooden box	Interface Mitutoyo	Interface USB	Accessories
G102	10	2,5 - 12,5	2,2 - 12,8	0,005	0,015	0,005	0,8	1,2	225	IP67	0,9	0,9	Chisel R0,1	0,7	0,5	12	[1]	E	1732-45	1962-10	1962-11	
H102	10	2,5 - 12,5	2,2 - 12,8	0,005	0,015	0,005	0,8	1,2	155	IP65	0,9	0,9	Chisel R0,1	0,7	0,5	12	[1]	M	1732-45			
G105	10	5 - 15	4,7 - 15,3	0,005	0,015	0,005	0,8	1,2	230	IP67	2,5	2,5	Ball Ø 0,6	2,3	0,8	35	[2]	E	1732-45	1962-10	1962-11	
H105	10	5 - 15	4,7 - 15,3	0,005	0,015	0,005	0,8	1,2	160	IP65	2,5	2,5	Ball Ø 0,6	2,3	0,8	35	[2]	M	1732-45			
G210	20	10 - 30	9,5 - 30,5	0,01	0,03	0,01	1,1	1,6	250	IP67	5,3	5,3	Ball Ø 1	5,2	1,2	85	[2]	E	1732-45	1962-10	1962-11	
H210	20	10 - 30	9,5 - 30,5	0,01	0,03	0,01	1,1	1,6	180	IP65	5,3	5,3	Ball Ø 1	5,2	1,2	85	[2]	M	1732-45			
G220	20	20 - 40	19,5 - 40,5	0,01	0,03	0,01	1,1	1,6	250	IP67	7,3	7,3	Ball Ø 1	7,0	1,2	85	[4]	E	1732-45	1962-10	1962-11	
H220	20	20 - 40	19,5 - 40,5	0,01	0,03	0,01	1,1	1,6	180	IP65	7,3	7,3	Ball Ø 1	7,0	1,2	85	[4]	M	1732-45			
G230	20	30 - 50	29,5 - 50,5	0,01	0,03	0,01	1,1	1,6	255	IP67	7,3	7,3	Ball Ø 1	7,0	1,2	85	[4]	E	1732-45	1962-10	1962-11	
H230	20	30 - 50	29,5 - 50,5	0,01	0,03	0,01	1,1	1,6	185	IP65	7,3	7,3	Ball Ø 1	7,0	1,2	85	[4]	M	1732-45			

Measuring contacts

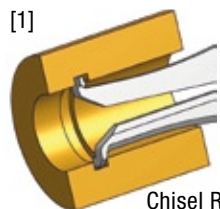

Chisel R 0,1 mm

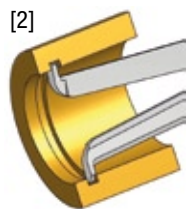

Ball Ø 0,6 mm
Ball Ø 1,0 mm

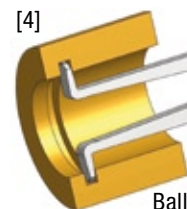

Ball Ø 1,0 mm

INTERNAL MEASUREMENT



G240



H240



F415



ID2015

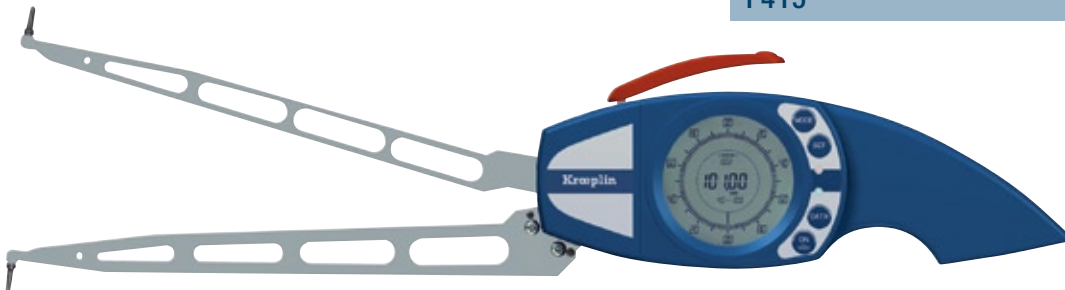

F640



ID2040

Measuring capacity

- Measuring contact movable Hb
- Measuring contact fixed Hf
- Measuring depth L
- Groove depth A
- Groove width B

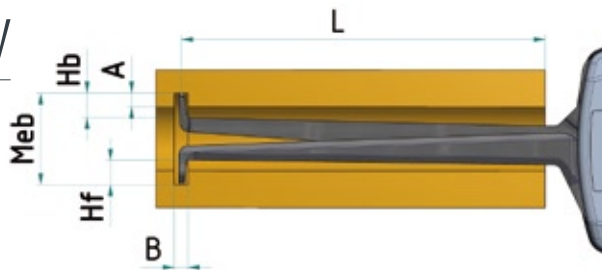

Application range up to 100 mm

	Measuring span Mes	Measuring range MeB	Range of indication Azb	Scale interval Skw	Permissible errors G	Repeatability limit r	Measuring force min.	Measuring force max.	Weight	Protection class	Measuring contact movable Hb	Measuring contact fixed Hf	Type of measuring contact	Groove depth A	Groove width B	Measuring depth L max.	Picture	Electronic E Mechanical M	Wooden box	Interface Mitutoyo	Interface USB
Type	[mm]	[mm]	[mm]	[mm]	[mm]	[mm]	[N]	[N]	[g]		[mm]	[mm]	[mm]	[mm]	[mm]	[mm]			Accessories		
G240	20	40 - 60	39,5 - 60,5	0,01	0,03	0,01	1,1	1,6	265	IP67	8,5	8,5	Ball Ø1	8,3	1,2	85	[5]	E	1732-45	1962-10	1962-11
H240	20	40 - 60	39,5 - 60,5	0,01	0,03	0,01	1,1	1,6	195	IP65	8,5	8,5	Ball Ø1	8,3	1,2	85	[5]	M	1732-45		
G250	20	50 - 70	49,5 - 70,5	0,01	0,03	0,01	1,1	1,6	265	IP67	8,5	8,5	Ball Ø1	8,3	1,2	85	[5]	E	1732-45	1962-10	1962-11
H250	20	50 - 70	49,5 - 70,5	0,01	0,03	0,01	1,1	1,6	195	IP65	8,5	8,5	Ball Ø1	8,3	1,2	85	[5]	M	1732-45		
G260	20	60 - 80	59,5 - 80,5	0,01	0,03	0,01	1,1	1,6	270	IP67	8,5	8,5	Ball Ø1	8,3	1,2	85	[5]	E	1732-45	1962-10	1962-11
H260	20	60 - 80	59,5 - 80,5	0,01	0,03	0,01	1,1	1,6	200	IP65	8,5	8,5	Ball Ø1	8,3	1,2	85	[5]	M	1732-45		
G270	20	70 - 90	69,5 - 90,5	0,01	0,03	0,01	1,1	1,6	270	IP67	8,5	8,5	Ball Ø1	8,3	1,2	85	[5]	E	1732-45	1962-10	1962-11
H270	20	70 - 90	69,5 - 90,5	0,01	0,03	0,01	1,1	1,6	200	IP65	8,5	8,5	Ball Ø1	8,3	1,2	85	[5]	M	1732-45		
G280	20	80 - 100	79,8 - 100,5	0,01	0,03	0,01	1,1	1,6	270	IP67	8,5	8,5	Ball Ø1	8,3	1,2	85	[5]	E	1732-45	1962-10	1962-11
H280	20	80 - 100	79,8 - 100,5	0,01	0,03	0,01	1,1	1,6	200	IP65	8,5	8,5	Ball Ø1	8,3	1,2	85	[5]	M	1732-45		
F415	40	15 - 55	14,5 - 55,5	0,02	0,04	0,02	1,2	1,7	360	IP63	6,0	6,0	Ball Ø1,5	5,0	1,8	115	[3]	E	1732-43	1960-90	1960-91
ID2015	50	15 - 65	14,5 - 65,5	0,05	0,05	0,025	1,2	2,0	400	-	5,3	5,3	Ball Ø1,5	5,0	1,8	175	[3]	M	1732-30		
F435	40	35 - 75	34,5 - 75,5	0,02	0,04	0,02	1,3	1,8	380	IP63	8,5	8,5	Ball Ø2	8,0	2,2	115	[5]	E	1732-43	1960-90	1960-91
ID2040	50	40 - 90	39,5 - 90,5	0,05	0,05	0,025	1,2	2,0	440	-	8,5	8,5	Ball Ø2	8,0	2,2	175	[5]	M	1732-30		
F455	40	55 - 95	54,5 - 95,5	0,02	0,04	0,02	1,3	1,8	380	IP63	8,5	8,5	Ball Ø2	8,0	2,2	115	[5]	E	1732-43	1960-90	1960-91
F615	60	15 - 75	14,5 - 75,5	0,02	0,06	0,04	1,0	1,2	440	IP63	6,0	6,0	Ball Ø1,5	5,0	1,8	175	[3]	E	HK	1960-90	1960-91
F640	60	40 - 100	39,5 - 100,5	0,02	0,06	0,04	1,0	1,2	440	IP63	8,5	8,5	Ball Ø2	8,0	2,2	195	[5]	E	HK	1960-90	1960-91

HK - wooden box is included in delivery

Measuring contacts

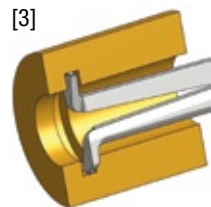

Ball Ø 1,0 mm
Ball Ø 1,5 mm

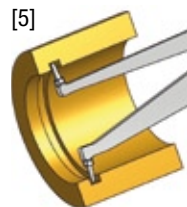

Ball Ø 1,0 mm
Ball Ø 2,0 mm

INTERNAL MEASUREMENT

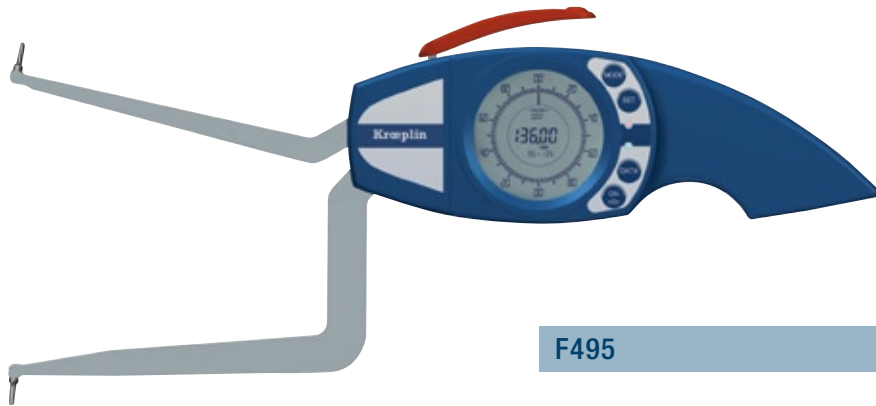

F495



ID20100

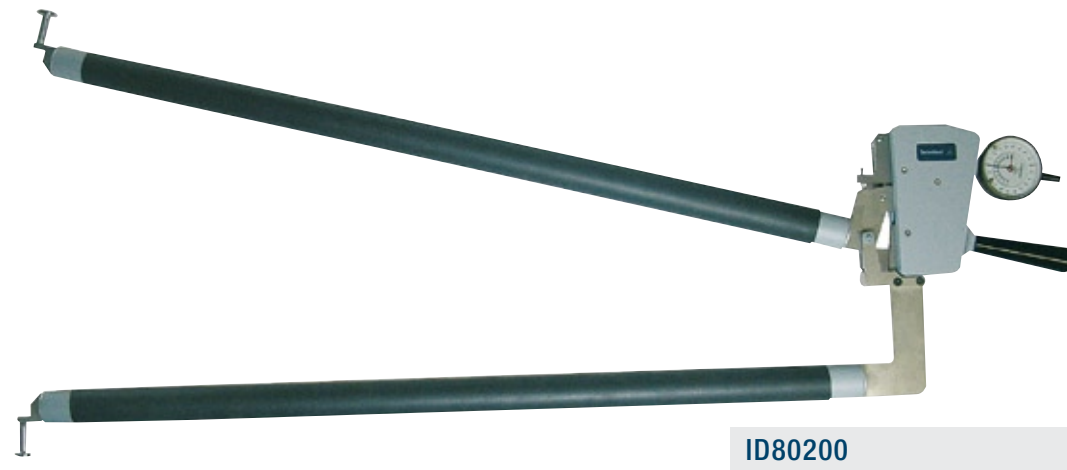

ID80200



ID20150

Measuring capacity

- Measuring contact movable Hb
- Measuring contact fixed Hf
- Measuring depth L
- Groove depth A
- Groove width B

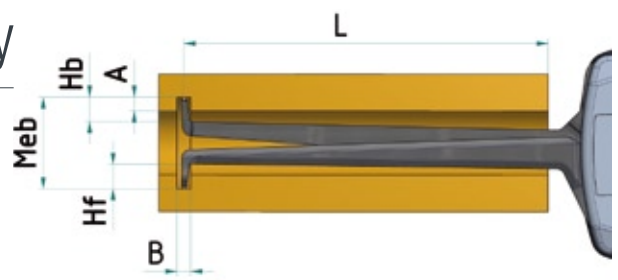

Application range up to 100 mm

Type	Measuring span Mes [mm]	Measuring range Meb [mm]	Range of indication AzB [mm]	Scale interval Skw [mm]	Permissible errors G [mm]	Repeatability limit r [mm]	Measuring force min. [N]	Measuring force max. [N]	Weight [g]	Protection class	Measuring contact movable Hb [mm]	Measuring contact fixed Hf [mm]	Type of measuring contact	Groove depth A [mm]	Groove width B [mm]	Measuring depth L max. [mm]	Picture	Electronic E Mechanical M	Wooden box	Interface Mitutoyo	Interface USB
F475	40	75 - 115	74,5 - 115,5	0,02	0,04	0,020	1,3	1,8	380	IP63	8,5	8,5	Ball Ø2	8,0	2,2	115	5	E	1732-43	1960-90	1960-91
ID2070	50	70 - 120	69,5 - 120,5	0,05	0,05	0,025	1,2	2,0	440	-	8,5	8,5	Ball Ø2	8,0	2,2	175	5	M	1732-30	-	-
F495	40	95 - 135	94,5 - 135,5	0,02	0,04	0,020	1,3	1,8	380	IP63	8,5	8,5	Ball Ø2	8,0	2,2	115	5	E	1732-43	1960-90	1960-91
ID20100	50	100 - 150	99,5 - 150,5	0,05	0,05	0,025	1,2	2,0	440	-	8,5	8,5	Ball Ø2	8,0	2,2	175	5	M	1732-30	-	-
ID20130	50	130 - 180	129,5 - 180,5	0,05	0,05	0,025	1,2	2,0	500	-	8,5	8,5	Ball Ø2	8,0	2,2	175	5	M	HK	-	-
ID20150	50	150 - 200	149,5 - 200,5	0,05	0,05	0,025	1,2	2,0	520	-	8,5	8,5	Ball Ø2	8,0	2,2	175	5	M	HK	-	-
ID20180	50	180 - 230	179,5 - 230,5	0,05	0,075	0,025	1,2	2,0	520	-	8,5	8,5	Ball Ø2	8,0	2,2	175	5	M	HK	-	-
ID4040	100	40 - 140	39,5 - 140,5	0,1	0,15	0,075	1,5	2,5	510	-	3,0	3,0	Ball Ø5	2,5	5,5	375	18	M	HK	-	-
ID4060	100	60 - 160	59,5 - 160,5	0,1	0,15	0,075	1,5	2,5	510	-	13,0	13,0	Ball Ø5	12,5	5,5	375	19	M	HK	-	-
ID6080	100	80 - 180	79,5 - 180,5	0,1	0,25	0,1	1,5	2,5	2000	-	12,0	12,0	Ball Ø5	11,0	5,5	535	19	M	HK	-	-
ID60150	100	150 - 250	149,5 - 250,5	0,1	0,3	0,1	1,5	2,5	2000	-	32,0	32,0	Ball Ø5	31,0	5,5	535	19	M	HK	-	-
ID60220	100	220 - 320	219,5 - 320,5	0,1	0,3	0,1	1,5	2,5	2000	-	32,0	32,0	Ball Ø5	31,0	5,5	535	19	M	HK	-	-
ID80200	200	200 - 400	199,5 - 400,5	0,2	0,4	0,2	1,0	2,0	2600	-	29,0	29,0	Hemisphere SR 20	28,0	21,0	735	20	M	HK	-	-

HK - wooden box is included in delivery

Measuring contacts

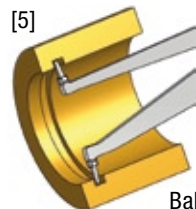

Ball Ø 2,0 mm

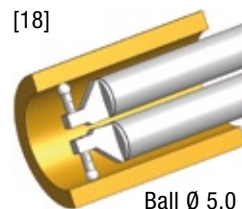

Ball Ø 5,0 mm

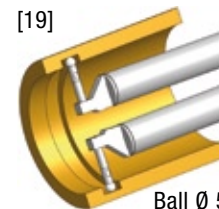

Ball Ø 5,0 mm

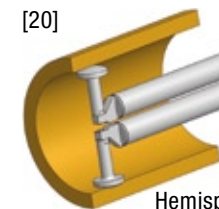

Hemisphere SR 20mm

INTERNAL COMPARISON MEASUREMENT



ID20M180



H2M50



H2M90



Measuring capacity

- Measuring contact movable Hb
- Measuring contact fixed Hf
- Measuring depth L
- Groove depth A
- Groove width B

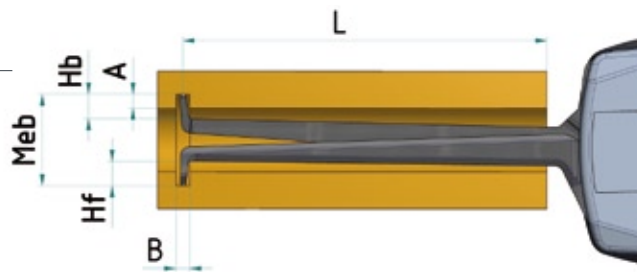

Application range variable

Type	Measuring span Mes [mm]	Measuring range Meb [mm]	Range of indication AzB [mm]	Scale interval Skw [mm]	Permissible errors G [mm]	Repeatability limit r [mm]	Measuring force min. [N]	Measuring force max. [N]	Weight [g]	Protection class	Measuring contact movable Hb [mm]	Measuring contact fixed Hf [mm]	Type of measuring contact [mm]	Groove depth A [mm]	Groove width B [mm]	Measuring depth L max. [mm]	Picture	Electronic E Mechanical M	Wooden box	Interface Mitutoyo	Interface USB	Accessories
H2M50	20	50 - 100	49,5 - 100,5	0,01	0,03	0,015	1,1	1,6	220	IP65	12,0	variable	Ball Ø1	8,3	1,2	85	[5]	M	HK	-	-	
H2M90	20	90 - 140	89,5 - 140,5	0,01	0,03	0,015	1,1	1,6	230	IP65	12,0	variable	Ball Ø1	8,3	1,2	85	[5]	M	HK	-	-	
H2M130	20	130 - 180	129,5 - 180,5	0,01	0,03	0,015	1,1	1,6	240	IP65	12,0	variable	Ball Ø1	8,3	1,2	85	[5]	M	HK	-	-	
ID20M180	50	180 - 310	179,5 - 310,5	0,05	0,075	0,05	1,2	2,0	520	-	30,0	variable	Ball Ø2	8,3	2,2	170	[5]	M	HK	-	-	
ID20M300	50	300 - 430	299,5 - 430,5	0,05	0,150	0,05	1,2	2,0	600	-	30,0	variable	Ball Ø2	8,3	2,2	170	[5]	M	HK	-	-	
ID20M420	50	420 - 550	419,5 - 550,5	0,05	0,250	0,05	1,2	2,0	600	-	30,0	variable	Ball Ø2	8,3	2,2	170	[5]	M	HK	-	-	

HK - wooden box is included in delivery

Measuring contacts

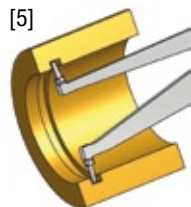

Ball Ø 1,0 mm
Ball Ø 2,0 mm

INTERNAL MEASUREMENT FOR BLIND HOLES



G2G30



H2G30

Measuring capacity

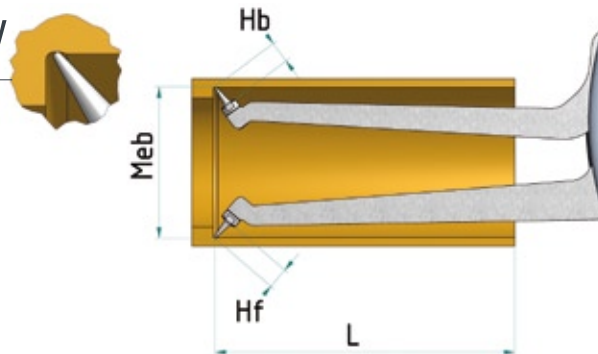

- Measuring contact movable Hb
- Measuring contact fixed Hf
- Measuring depth L

Application range from 20 mm to 100 mm

	Measuring span Mes	Measuring range Meb	Range of indication Azb	Scale interval Skw	Permissible errors G	Repeatability limit r	Measuring force min.	Measuring force max.	Weight	Protection class	Measuring contact movable Hb	Measuring contact fixed Hf	Type of measuring contact		Measuring depth L max.	Picture	Electronic E Mechanical M	Wooden box	Interface Mitutoyo	Interface USB
Type	[mm]	[mm]	[mm]	[mm]	[mm]	[mm]	[N]	[N]	[g]		[mm]	[mm]	[mm]	[mm]	[mm]			Accessories		
G2G20	20	20 - 40	19,5 - 40,5	0,01	0,03	0,01	1,1	1,6	250	IP67	5,0	5,0	Conus SR = 0,2	ø1,6	85	[13]	E	1732-45	1962-10	1962-11
H2G20	20	20 - 40	19,5 - 40,5	0,01	0,03	0,01	1,1	1,6	180	IP65	5,0	5,0	Conus SR = 0,2	ø1,6	85	[13]	M	1732-45		
G2G30	20	30 - 50	29,5 - 50,5	0,01	0,03	0,01	1,1	1,6	255	IP67	5,0	5,0	Conus SR = 0,2	ø1,6	85	[13]	E	1732-45	1962-10	1962-11
H2G30	20	30 - 50	29,5 - 50,5	0,01	0,03	0,01	1,1	1,6	185	IP65	5,0	5,0	Conus SR = 0,2	ø1,6	85	[13]	M	1732-45		
G2G40	20	40 - 60	39,5 - 60,5	0,01	0,03	0,01	1,1	1,6	265	IP67	5,0	5,0	Conus SR = 0,2	ø1,6	85	[13]	E	1732-45	1962-10	1962-11
H2G40	20	40 - 60	39,5 - 60,5	0,01	0,03	0,01	1,1	1,6	195	IP65	5,0	5,0	Conus SR = 0,2	ø1,6	85	[13]	M	1732-45		
G2G50	20	50 - 70	49,5 - 70,5	0,01	0,03	0,01	1,1	1,6	265	IP67	5,0	5,0	Conus SR = 0,2	ø1,6	85	[13]	E	1732-45	1962-10	1962-11
H2G50	20	50 - 70	49,5 - 70,5	0,01	0,03	0,01	1,1	1,6	195	IP65	5,0	5,0	Conus SR = 0,2	ø1,6	85	[13]	M	1732-45		
G2G60	20	60 - 80	59,5 - 80,5	0,01	0,03	0,01	1,1	1,6	270	IP67	5,0	5,0	Conus SR = 0,2	ø1,6	85	[13]	E	1732-45	1962-10	1962-11
H2G60	20	60 - 80	59,5 - 80,5	0,01	0,03	0,01	1,1	1,6	200	IP65	5,0	5,0	Conus SR = 0,2	ø1,6	85	[13]	M	1732-45		
G2G70	20	70 - 90	69,5 - 90,5	0,01	0,03	0,01	1,1	1,6	270	IP67	5,0	5,0	Conus SR = 0,2	ø1,6	85	[13]	E	1732-45	1962-10	1962-11
H2G70	20	70 - 90	69,5 - 90,5	0,01	0,03	0,01	1,1	1,6	200	IP65	5,0	5,0	Conus SR = 0,2	ø1,6	85	[13]	M	1732-45		
G2G80	20	80 - 100	79,8 - 100,5	0,01	0,03	0,01	1,1	1,6	270	IP67	5,0	5,0	Conus SR = 0,2	ø1,6	85	[13]	E	1732-45	1962-10	1962-11
H2G80	20	80 - 100	79,8 - 100,5	0,01	0,03	0,01	1,1	1,6	200	IP65	5,0	5,0	Conus SR = 0,2	ø1,6	85	[13]	M	1732-45		

Measuring contacts

[13]

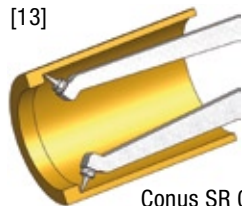

Conus SR 0,2 mm

EXTERNAL MEASUREMENT



C110



D110



C220



D220

Measuring capacity

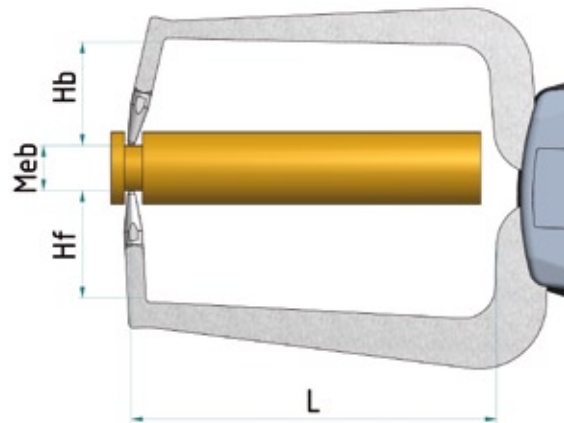

Measuring depth L
 Measuring contact movable Hb
 Measuring contact fixed Hf



POC02K



POC02F



POC02N

Application range up to 20 mm

	Measuring span Mes	Measuring range Meb	Range of indication Azb	Scale interval Skw	Permissible errors G	Repeatability limit r	Measuring force min.	Measuring force max.	Weight	Protection class	Measuring contact movable Hb	Measuring contact fixed Hf	Type of measuring contact	Measuring depth L max.	Picture	Electronic E Mechanical M	Wooden box	Interface Mitutoyo	Interface USB
Type	[mm]	[mm]	[mm]	[mm]	[mm]	[mm]	[N]	[N]	[g]		[mm]	[mm]	[mm]	[mm]			Accessories		
C110	10	0 - 10	0 - 10,5	0,005	0,015	0,005	0,8	1,2	240	IP67	19,1	18,6	Ball Ø1,5	35	[6]	E	1732-45	1962-10	1962-11
D110	10	0 - 10	0 - 10,5	0,005	0,015	0,005	0,8	1,2	170	IP65	19,1	18,6	Ball Ø1,5	35	[6]	M	1732-45	-	-
C110S	10	0 - 10	0 - 10,5	0,005	0,015	0,005	0,8	1,2	240	IP67	18,8	18,5	Chisel R 0,4	35	[7]	E	1732-45	1962-10	1962-11
D110S	10	0 - 10	0 - 10,5	0,005	0,015	0,005	0,8	1,2	170	IP65	18,8	18,5	Chisel R 0,4	35	[7]	M	1732-45	-	-
C220	20	0 - 20	0 - 20,5	0,01	0,03	0,01	1,1	1,6	280	IP67	24,7	24,6	Ball Ø1,5	85	[6]	E	1732-45	1962-10	1962-11
D220	20	0 - 20	0 - 20,5	0,01	0,03	0,01	1,1	1,6	210	IP65	24,7	24,6	Ball Ø1,5	85	[6]	M	1732-45	-	-
C220S	20	0 - 20	0 - 20,5	0,01	0,03	0,01	1,1	1,6	280	IP67	24,7	24,6	Chisel R 0,4	85	[7]	E	1732-45	1962-10	1962-11
D220S	20	0 - 20	0 - 20,5	0,01	0,03	0,01	1,1	1,6	210	IP65	24,7	24,6	Chisel R 0,4	85	[7]	M	1732-45	-	-
POCO 2K	10	0 - 10	0 - >10	0,1	0,1	0,05	0,3	1,3	40	-	5	5	Ball Ø5	36	[23]	M	1732-01	-	-
POCO 2N	10	0 - 10	0 - >10	0,1	0,1	0,05	0,3	1,3	40	-	3,5	3,5	Needle Ø 0,75	36	[24]	M	1732-01	-	-
POCO 2F	10	0 - 10	0 - >10	0,1	0,1	0,05	0,3	1,3	40	-	4,5	4,5	Ch-R 0,5 / P Ø3,5	36	[25]	M	1732-01	-	-

Measuring contacts



Ball
Ø 1,5 mm

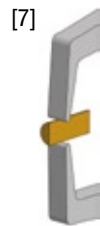

Chisel
R 0,4 mm

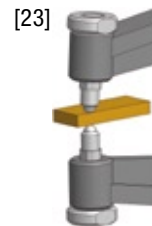

Ball
Ø 5,0 mm

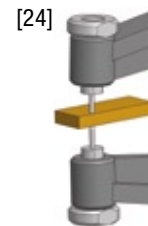

Needle
Ø 0,75 mm

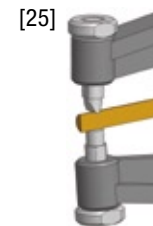

Chisel R 0,5 mm
Plane Ø 3,5 mm

EXTERNAL MEASUREMENT



B440

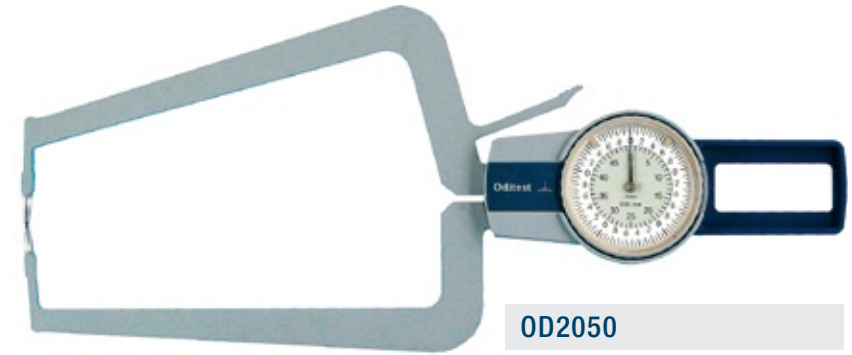

OD2050

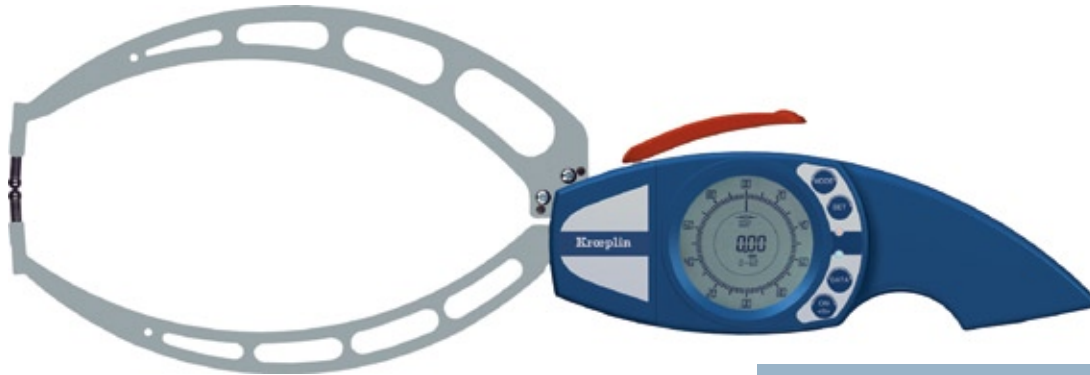

B660

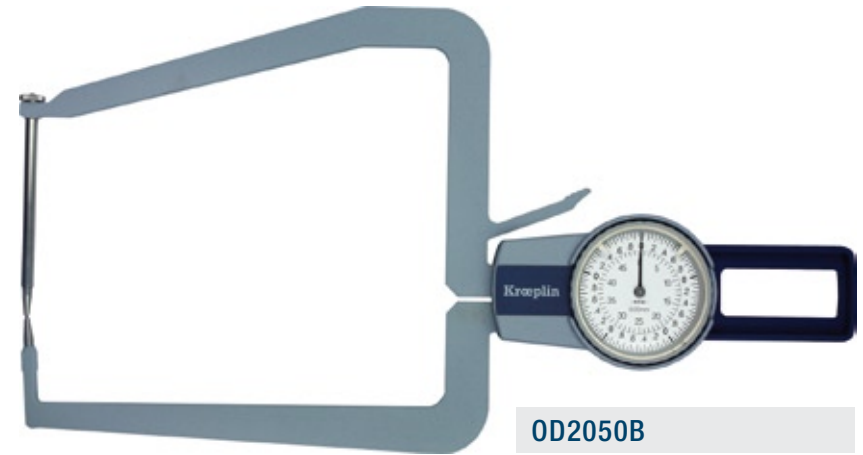

OD2050B

Measuring capacity

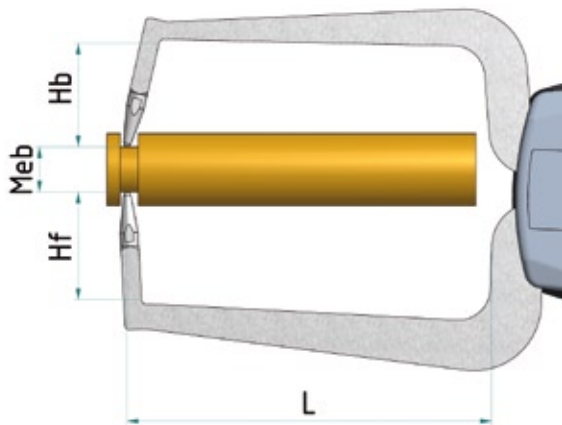

Measuring depth L
Measuring contact movable Hb
Measuring contact fixed Hf

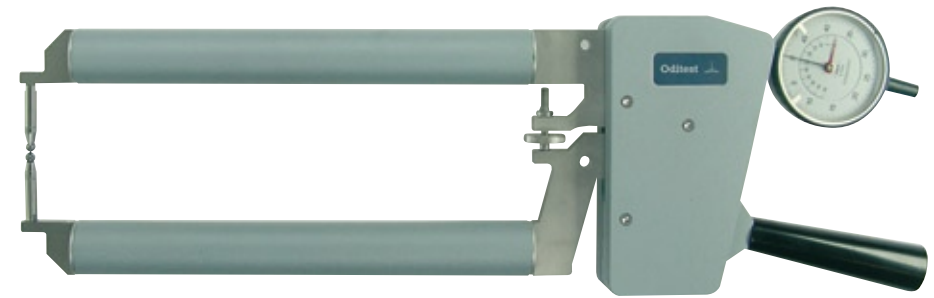

OD3050

Application range up to 200 mm

	Measuring span Mes	Measuring range MeB	Range of indication Azb	Scale interval Skw	Permissible errors G	Repeatability limit r	Measuring force min.	Measuring force max.	Weight	Protection class	Measuring contact movable Hb	Measuring contact fixed Hf	Type of measuring contact	Measuring depth L max.	Picture	Electronic E Mechanical M	Wooden box	Interface Mitutoyo	Interface USB
Type	[mm]	[mm]	[mm]	[mm]	[mm]	[mm]	[N]	[N]	[g]		[mm]	[mm]	[mm]	[mm]			Accessories		
B440	40	0 - 40	0 - 41	0,02	0,04	0,02	1,0	1,5	380	IP63	24,9	25,4	Ball Ø3	115	[6]	E	1732-43	1960-90	1960-91
OD2050	50	0 - 50	0 - 50,5	0,05	0,05	0,025	1,2	1,8	560	-	32	35	Ball Ø2	173	[6]	M	1732-30	-	-
B440S	40	0 - 40	0 - 41	0,02	0,04	0,02	1,0	1,5	380	IP63	25	25,4	Chisel R 0,75	115	[7]	E	1732-43	1960-90	1960-91
OD2050S	50	0 - 50	0 - 50,5	0,05	0,05	0,025	1,2	1,8	560	-	32	32	Chisel R 0,75	173	[7]	M	1732-30	-	-
OD2050B	50	0 - 50	0 - 50,5	0,05	0,075	0,025	1,2	1,8	560	-	83	35	Ball Ø2	173	[6]	M	HK	-	-
OD2050F80	50	0 - 50	0 - 50,5	0,05	0,075	0,025	1,2	1,8	580	-	32	83	Ball Ø2	173	[6]	M	HK	-	-
OD2050F130	50	0 - 50	0 - 50,5	0,05	0,075	0,05	1,2	1,8	600	-	32	133	Ball Ø2	173	[6]	M	HK	-	-
OD2050BF80	50	0 - 50	0 - 50,5	0,05	0,075	0,05	1,2	1,8	580	-	83	83	Ball Ø2	173	[6]	M	HK	-	-
OD2050BF130	50	0 - 50	0 - 50,5	0,05	0,075	0,05	1,2	1,8	600	-	83	133	Ball Ø2	173	[6]	M	HK	-	-
OD3050	50	0 - 50	0 - > 50	0,1	0,15	0,075	1,5	2,5	1600	-	32	32	Ball Ø5	230	[16]	M	HK	-	-
B660	60	0 - 60	0 - 61	0,02	0,06	0,04	0,9	1,2	470	IP63	25	25	Ball Ø5	190	[6]	E	HK	1960-90	1960-91
OD20100	50	50 - 100	49,5 - 100,5	0,05	0,075	0,025	1,2	1,8	580	-	32	32	Ball Ø2	173	[6]	M	HK	-	-
OD20150	50	100 - 150	99,5 - 150,5	0,05	0,075	0,05	1,2	1,8	600	-	32	32	Ball Ø2	173	[6]	M	HK	-	-
OD20100F80	50	50 - 100	49,5 - 100,5	0,05	0,075	0,05	1,2	1,8	600	-	32	83	Ball Ø2	173	[6]	M	HK	-	-
OD40100	100	0 - 100	0 - > 100	0,1	0,15	0,075	1,5	2,5	680	-	32	32	Ball Ø5	372	[16]	M	HK	-	-
OD60100	100	0 - 100	0 - > 100	0,1	0,3	0,15	1,5	2,5	2000	-	32	32	Ball Ø5	530	[16]	M	HK	-	-
OD60100BJ	100	0 - 100	0 - > 100	0,1	0,3	0,15	1,5	2,5	2000	-	32	132	Ball Ø5	530	[16]	M	HK	-	-
OD80200	200	0 - 200	0 - > 200	0,2	0,4	0,2	1,0	2,0	3000	-	100	100	Hemisphere SR 20	725	[17]	M	HK	-	-

Measuring contacts

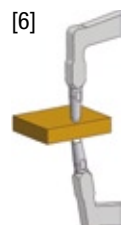

Ball
Ø 2,0 mm
Ø 3,0 mm
Ø 5,0 mm



Chisel
R 0,75 mm



Ball
Ø 5,0 mm



Hemisphere
SR 20 mm

HK - wooden box is included in delivery

TUBE WALL MEASUREMENT



C1R10



D2R20



B4R40



OD2050R

Measuring capacity

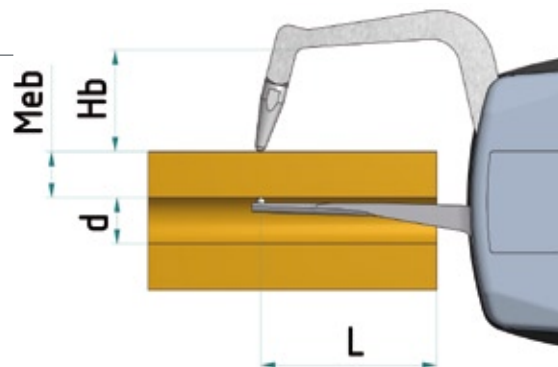

Measuring depth L
 Measuring contact movable Hb
 Measuring contact fixed Hf
 Diameter d



POC02R

Application range up to 100 mm

Type	Measuring span Mes [mm]	Measuring range Meb [mm]	Range of indication Azb [mm]	Scale interval Skw [mm]	Permissible errors G [mm]	Repeatability limit r [mm]	Measuring force min. [N]	Measuring force max. [N]	Weight [g]	Protection class	Type of measuring contact movable [mm]	Measuring contact movable Hb [mm]	Type of measuring contact fixed [mm]	Measuring contact fixed Hf [mm]	Measuring depth L max. [mm]	Picture	Electronic E Mechanical M	Wooden box	Interface Mitutoyo	Interface USB	Accessories
C1R10	10	0 - 10	0 - 10,5	0,005	0,015	0,005	0,8	1,2	235	IP67	Ball Ø 1,5	19,1	Ball Ø 1,5	0,9	3	35	[8]	E	1732-45	1962-10	1962-11
D1R10	10	0 - 10	0 - 10,5	0,005	0,015	0,005	0,8	1,2	165	IP65	Ball Ø 1,5	19,1	Ball Ø 1,5	0,9	3	35	[8]	M	1732-45	-	-
C1R10S	10	0 - 10	0 - 10,5	0,005	0,015	0,005	0,8	1,2	235	IP67	Chisel R = 0,4	18,8	Ball Ø 1,5	0,9	3	35	[9]	E	1732-45	1962-10	1962-11
D1R10S	10	0 - 10	0 - 10,5	0,005	0,015	0,005	0,8	1,2	165	IP65	Chisel R = 0,4	18,8	Ball Ø 1,5	0,9	3	35	[9]	M	1732-45	-	-
C2R20	20	0 - 20	0 - 20,5	0,01	0,03	0,01	1,1	1,6	270	IP67	Ball Ø 1,5	24,7	Ball Ø 1,5	2,5	9	80	[10]	E	1732-45	1962-10	1962-11
D2R20	20	0 - 20	0 - 20,5	0,01	0,03	0,01	1,1	1,6	200	IP65	Ball Ø 1,5	24,7	Ball Ø 1,5	2,5	9	80	[10]	M	1732-45	-	-
C2R20S	20	0 - 20	0 - 20,5	0,01	0,03	0,01	1,1	1,6	270	IP67	Chisel R = 0,4	24,7	Ball Ø 1,5	2,5	9	80	[11]	E	1732-45	1962-10	1962-11
D2R20S	20	0 - 20	0 - 20,5	0,01	0,03	0,01	1,1	1,6	200	IP65	Chisel R = 0,4	24,7	Ball Ø 1,5	2,5	9	80	[11]	M	1732-45	-	-
B4R40	40	0 - 40	0 - 41,0	0,02	0,04	0,02	1,0	1,5	380	IP63	Ball Ø 3,0	32,0	Ball Ø 3,0	3,5	10	100	[10]	E	1732-43	1960-90	1960-91
OD2050R	50	0 - 50	0 - 50,5	0,05	0,05	0,025	1,2	1,8	520	-	Ball Ø 2,0	32,0	Ball Ø 2,0	3,5	10	100	[10]	M	1732-30	-	-
B4R40S	40	0 - 40	0 - 41,0	0,02	0,04	0,02	1,0	1,5	380	IP63	Chisel R = 0,75	25,0	Ball Ø 3,0	3,5	10	100	[11]	E	1732-43	1960-90	1960-91
OD2050RS	50	0 - 50	0 - 50,5	0,05	0,05	0,025	1,2	1,8	520	-	Chisel R = 0,75	32,0	Ball Ø 2,0	3,5	10	100	[11]	M	1732-30	-	-
B6R60	60	0 - 60	0 - 61,0	0,02	0,06	0,04	0,9	1,2	470	IP63	Ball Ø 5,0	25,0	Ball Ø 3,0	3,5	10	150	[10]	E	HK	1960-90	1960-91
OD2050BR	50	0 - 50	0 - 50,5	0,05	0,075	0,025	1,2	1,8	560	-	Ball Ø 2,0	83,0	Ball Ø 2,0	3,5	10	100	[10]	M	HK	-	-
OD40100R	100	0 - 100	0 - 102,0	0,1	0,15	0,075	1,5	2,5	680	-	Ball Ø 5,0	32,0	Ball Ø 5,0	12,0	35	350	[15]	M	HK	-	-
POCO 2R	10	0 - 10	0 - > 10	0,1	0,1	0,05	0,3	1,3	40	-	Ball Ø 2,0	5,0	Hemisphere SR = 0,5	0,8	3	25	[21]	M	1732-01	-	-

HK - wooden box is included in delivery

Measuring contacts

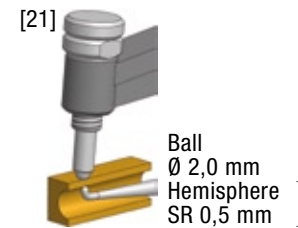
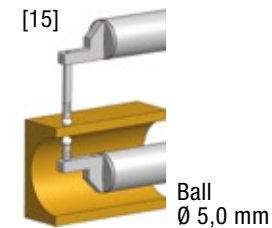
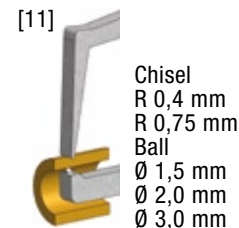
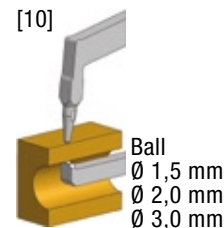
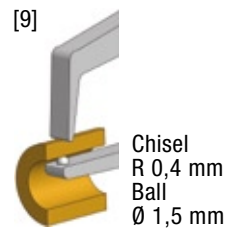
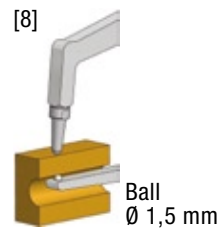

MEASUREMENT OF FOAMED MATERIAL AND FOILS



C110T



D110T



B660T

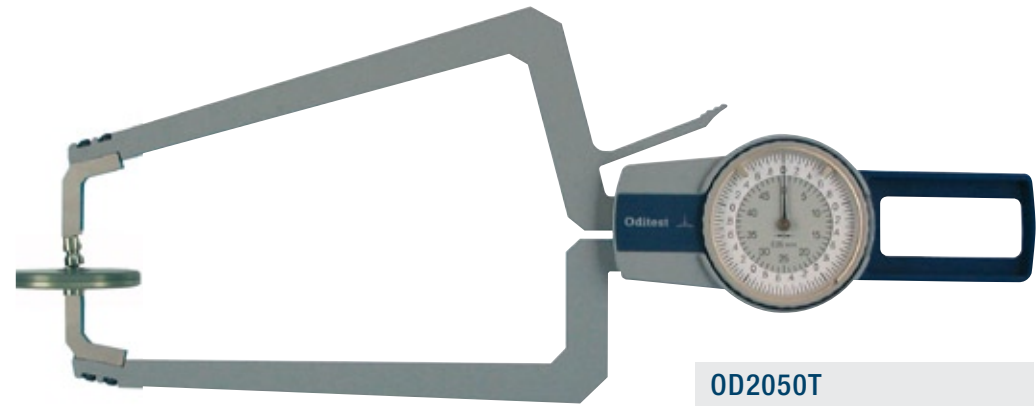

OD2050T

Measuring capacity

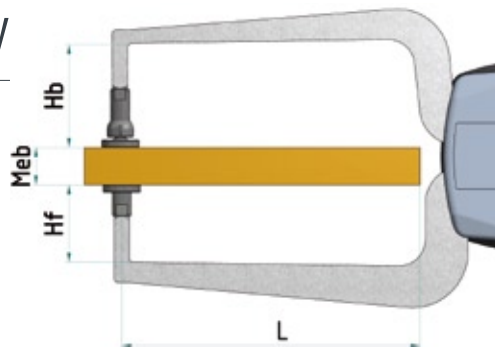

Measuring depth L
 Measuring contact movable Hb
 Measuring contact fixed Hf



POC02T

Application range up to 100

Type	Measuring span Mes [mm]	Measuring range Meb [mm]	Range of indication AzB [mm]	Scale interval Skw [mm]	Permissible errors G [mm]	Repeatability limit r [mm]	Measuring force min. [N]	Measuring force max. [N]	Weight [g]	Protection class	Measuring contact movable Hb [mm]	Measuring contact fixed Hf [mm]	Type of measuring contact [mm]	Measuring depth L max. [mm]	Picture	Electronic E Mechanical M	Wooden box	Interface Mitutoyo	Interface USB
C110T	10	0 - 10	0 - 10,5	0,005	0,02	0,005	0,8	1,2	175	IP67	21,7	14,8	Flat Ø 6	35	[12]	E	1732-45	1962-10	1962-11
D110T	10	0 - 10	0 - 10,5	0,005	0,02	0,005	0,8	1,2	175	IP65	21,7	14,8	Flat Ø 6	35	[12]	M	1732-45	-	-
C220T	20	0 - 20	0 - 20,5	0,01	0,04	0,01	1,1	1,6	220	IP67	28,2	20,7	Flat Ø 10	85	[12]	E	1732-45	1962-10	1962-11
D220T	20	0 - 20	0 - 20,5	0,01	0,04	0,01	1,1	1,6	220	IP65	28,2	20,7	Flat Ø 10	85	[12]	M	1732-45	-	-
B440T	40	0 - 40	0 - 41	0,02	0,04	0,02	1,0	1,5	380	IP63	30,0	19,4	Flat Ø 50	115	[14]	E	1732-43	1960-90	1960-91
OD2050T	50	0 - 50	0 - 50,5	0,05	0,1	0,025	1,2	1,8	600	-	35,0	23,0	Flat Ø 50	173	[14]	M	1732-30	-	-
B660T	60	0 - 60	0 - 61	0,02	0,08	0,06	0,6	1,0	470	IP63	27,0	19,5	Flat Ø 50	190	[14]	E	HK	1960-90	1960-91
OD20100T	50	50 - 100	49,5 - 100,5	0,05	0,1	0,05	1,2	1,8	630	-	35,0	23,0	Flat Ø 50	173	[14]	M	HK	-	-
OD40100T	100	0 - 100	0 - 102	0,1	0,15	0,075	1,5	2,5	680	-	86,0	6,0	Flat Ø 50	368	[14]	M	HK	-	-
OD60100T	100	0 - 100	0 - 102	0,1	0,4	0,15	1,5	2,5	2000	-	46,0	26,0	Flat Ø 50	530	[14]	M	HK	-	-
POCO 2T	10	0 - 10	0 - >10	0,1	0,1	0,05	0,3	1,3	40	-	5,0	5,0	Flat Ø 10	36	[22]	M	1732-01	-	-

HK - wooden box is included in delivery

Measuring contacts

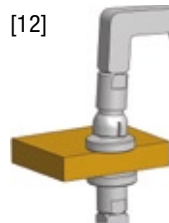

Flat Ø 6 mm
Flat Ø 10 mm

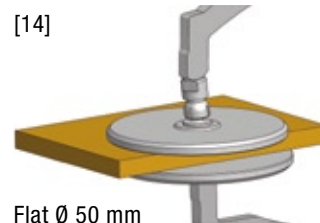

Flat Ø 50 mm



Flat Ø 10 mm

SPECIAL GAUGES

We are always searching for the best solution for your measuring problem, either mechanical or electronic. In order to enable us to find the solution together and to design your special gauge, please kindly send us a drawing of the object to be measured and indicate tolerance and measuring force, and if possible, send us a sample of the part to be measured. Full information in your enquiry enables us to put forward the optimum design solution for your application.

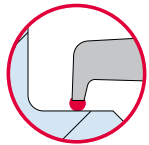
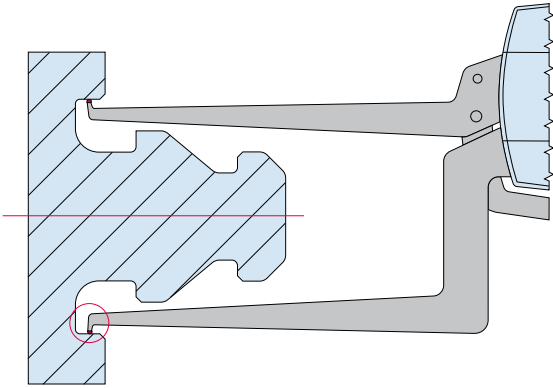

Measurement at difficultly accessible places with specially designed caliper arms

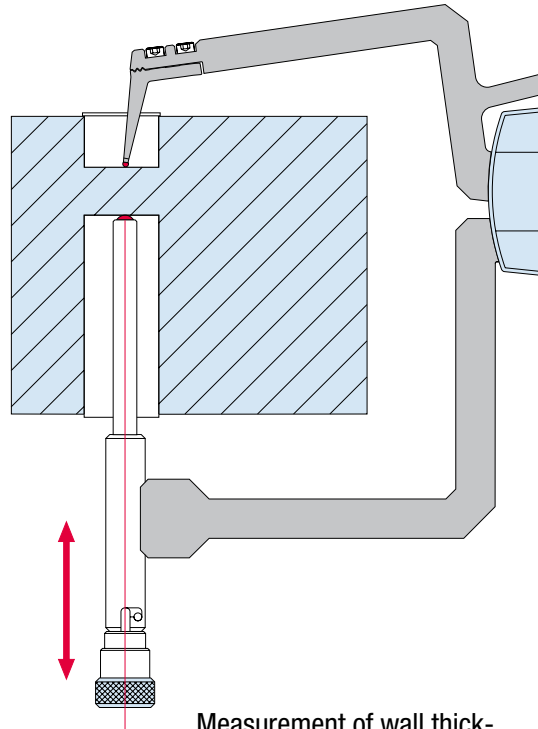

Measurement of wall thicknesses at large undercuts with bayonet-type contacts (displacement in direction of the arrow before and after the measurement)

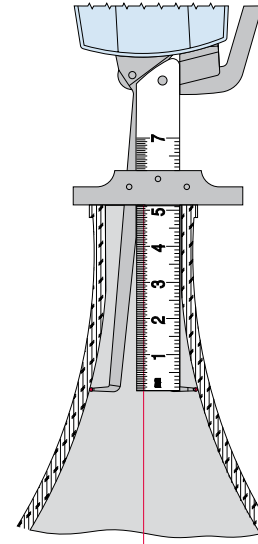

Measurement of bottle diameters with depth measurement

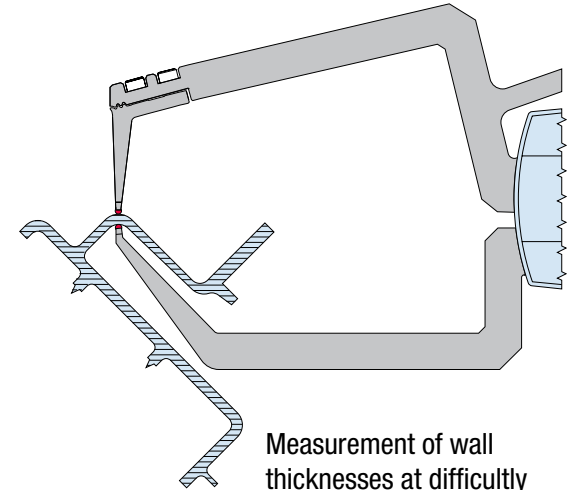

Measurement of wall thicknesses at difficultly accessible places

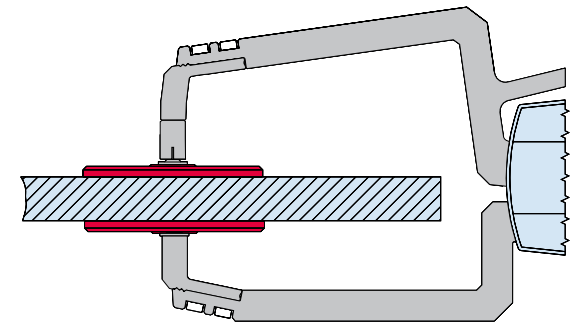

Measurement of foam materials with flat contacts and reduced measuring force

Accessories

Interface Mitutoyo
 Order code: 1962-11 (series C and G)
 Order code: 1960-90 (series B and F)

Interface USB
 Order code: 1962-10 (series C and G)
 Order code: 1960-91 (series B and F)

Holding unit for the series C, G, D, H
 Order code: 8004-50

Wooden boxes for all series
 For order code please see technical details
 (HK = wooden box is included in delivery)



Wooden box available on request

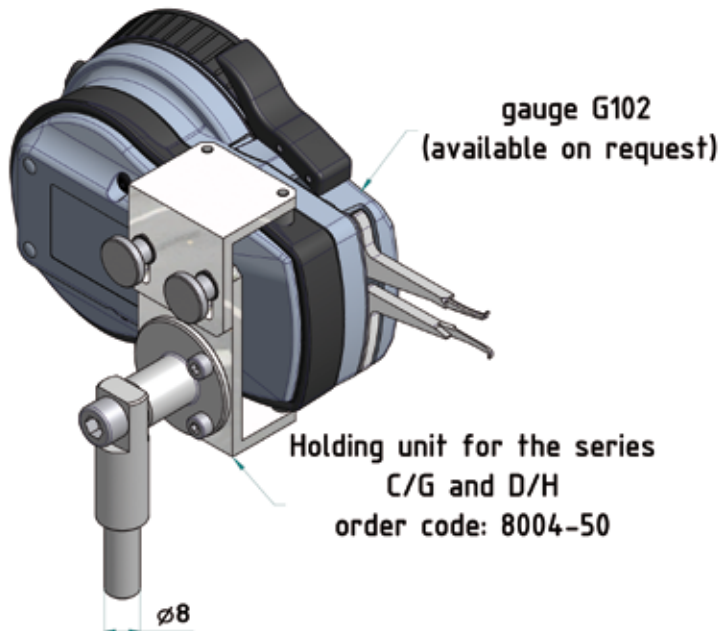

gauge G102 (available on request)

Holding unit for the series C/G and D/H
 order code: 8004-50

For measuring small parts the holding unit enables the gauge (series C, G, D, H) to be used with a measuring stand

Interfaces for the electronic gauges series B and F

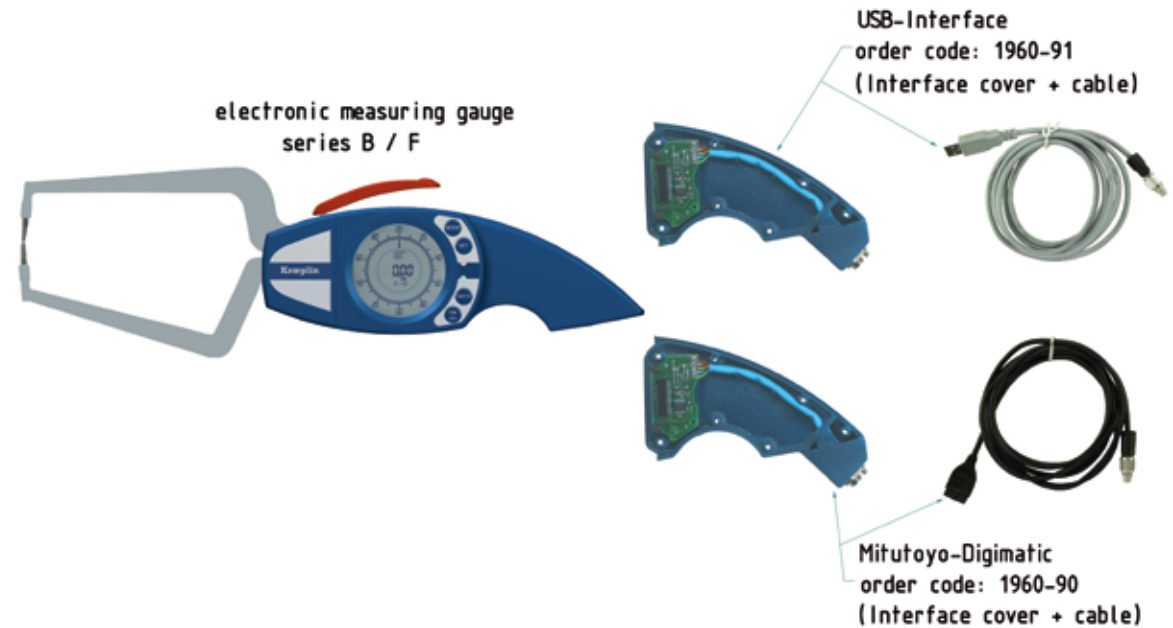

electronic measuring gauge series B / F

USB-Interface
 order code: 1960-91
 (Interface cover + cable)

Mitutoyo-Digimatic
 order code: 1960-90
 (Interface cover + cable)

Interfaces for the electronic gauges series C and G

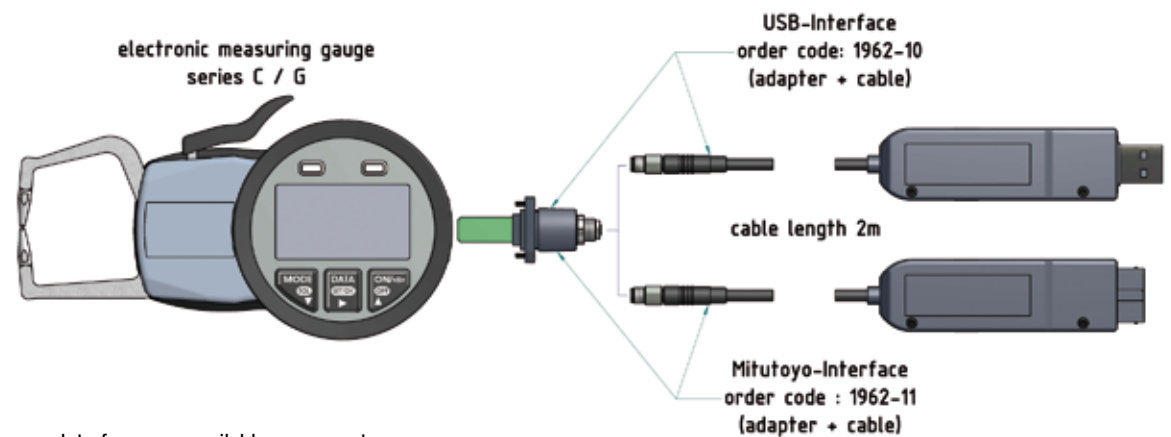

electronic measuring gauge series C / G

USB-Interface
 order code: 1962-10
 (adapter + cable)

cable length 2m

Mitutoyo-Interface
 order code : 1962-11
 (adapter + cable)

Interfaces are available on request.
 An evaluation software for the USB interface is included in delivery.



Kroeplin

Längenmesstechnik

Application area

- **Mechanical engineering**
- **Automobile industry**
- **Aerospace industry**
- **Wire manufacturers:** Diameter determination of continuous wires.
- **Glass industry:** Measurement of wall thicknesses in difficult accessible places.
- **Dental laboratories:** Measurement of tooth crown thicknesses.
- **Aerosol and packaging industry:** Measurement of aerosol cans.
- **Foundries:** Measurement of cast wall thicknesses.
- **Key manufacturers:** Measurement of milled notches of keys.
- **Foamed material industry:** Measurements of foamed material thicknesses.
- **Tube manufacturers:** Internal and external measurements, also of extremely wide tubes.
- **Ceramic industry:** Safe and simple determination of contraction due to baking and drying.
- **Gun clubs:** Checking of the admissible thickness of shooting jackets.
- **Medical institutes:** Measurement of skin wrinkles of men and animals.
- **Special designs:** Your measuring task is among them.

